

**marathon**<sup>™</sup>  
Generators

SE350  
Voltage Regulator  
Instruction Manual



A Regal Brand

**REGAL**

## INTRODUCTION

The SE350E voltage regulator is an encapsulated electronic voltage regulator which controls the output of a brushless AC generator by regulating the current into the exciter field.

SPECIFICATION	SE350E REGULATOR
Sensing (Average) & Power Input	190-240 Vac
Burden	500 VA
Output Power - Continuous	73 Vdc at 3.5 Adc (255w)
Output Power - Forcing (240 Vac Input Power)	105 Vdc at 5 Adc (525w)
Regulation	1.0%
Exciter Field Resistance	15 ohms minimum
Remote Voltage Adjustment Range	±10% with 2000 ohm rheostat ±5% with 1000 ohm rheostat
Frequency Compensation	Adjustable
Roll Off Frequency	54-61 Hz for 60 Hz Operation 45-51 Hz for 50 Hz Operation
Weight	7.4 oz.
Operating Temperature	-40°C to 60°C
Storage Temperature	-65°C to +85°C
Power Dissipation	8 watts maximum
Size	3.9"Lx2.66"Wx2.20"H
Voltage Build up	Internal provisions for automatic voltage build up from generator residual voltage as low as 10 Vac.
EMI Suppression	Internal electromagnetic interference filter (EMI Filter).

### WARNING

TO PREVENT PERSONAL INJURY OR EQUIPMENT DAMAGE, ONLY QUALIFIED PERSONNEL SHOULD INSTALL, OPERATE, OR SERVICE THIS DEVICE.

### CAUTION

DO NOT megger or high-pot the generator with the regulator connected. DO NOT high-pot the regulator.

## INSTALLATION

### MOUNTING

The SE350E voltage regulator can be mounted in any plane. See Figure 1 for mounting dimensions.

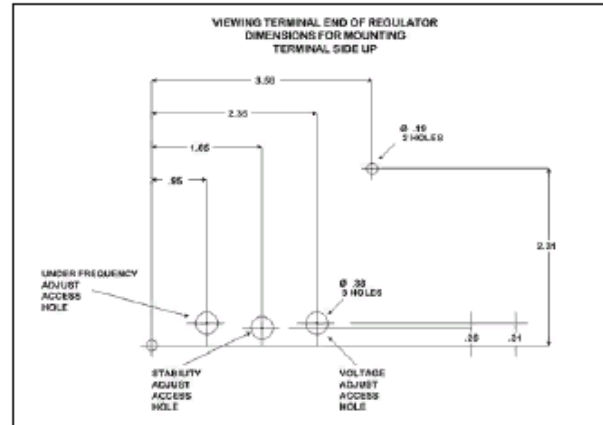

Figure 1

### EXCITER POWER CIRCUIT

Connect the regulator wire F+ to the generator F+ or F1 field terminal. Connect the regulator wire F- to the generator F- or F2 field terminal. See Figure 2 for typical connection diagram.

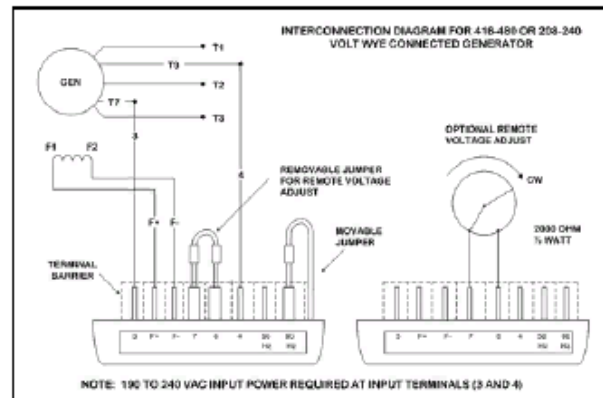

Figure 2

### SENSING / POWER INPUT CIRCUIT

Input power and sensing is achieved through terminals 3 and 4. The voltage input requirement of the SE350E is 190 to 240 vac.

See Figure 2 for typical connection diagram.

### FUSE

A 4 Amp 250V - 5 X 20 mm fuse is supplied with the regulator (Part A-527066).

## VOLTAGE ADJUST

The screwdriver adjustable potentiometer adjusts the generator output voltage. Adjustment clockwise increases the generator output voltage.

When using a remote voltage adjust rheostat, remove the jumper wire across terminals 6 and 7 and install a 2000 ohm 1/2 watt (minimum) rheostat. (See Figure 2). This will give  $\pm 10\%$  voltage variation from the nominal. (For  $\pm 5\%$  voltage variation use a 1000 ohm 1/2 watt rheostat).

## STABILITY ADJUST

System stability is the ability of the generator to respond to load transients. Decreasing the stability makes the generator less sluggish and faster to respond to load transients. If the stability of the regulator is decreased too much, the generator will tend to hunt under steady state conditions.

The screwdriver adjustable potentiometer adjusts the system stability. Adjustment clockwise increases the stability. Increasing the stability increases the response time of the generator. Conversely, decreasing the stability decreases the response time of the generator.

Stability Selection (On applicable regulator models)

When excitation under voltage, it can result in insufficient adjustment range for stability adjustment and when excitation over voltage, the response from the AVR becomes sluggish. The AVR is equipped with 2 bridging wires J1 and J2 to help improve this problem. See Figure 2.

- If the unloaded excitation voltage is less than 7 VDC, please cut open the J2 red bridging wires.
- If the unloaded excitation voltage is greater than 25 VDC, please cut open the J1 white bridging wires.

## V/Hz ROLL-OFF FREQUENCY SELECTION

The roll-off point is the frequency where the generator voltage starts to decrease. This reduces the Kilowatt load to the engine, which allows the engine to recover in speed under any load transient condition.

Use jumper to select 50 Hz or 60 Hz. The screwdriver adjustable potentiometer sets the roll-off frequency from 54-61 Hz in the 60 Hz setting or from 45-51 Hz in the 50 Hz setting.

The SE350E has the roll-off point preset to 58 Hz in the 60 Hz mode and 48 Hz in the 50 Hz mode. To change the roll-off point, adjust engine speed to the desired rated speed. (50 or 60 Hz). Set the voltage to the desired setting at rated speed. Adjust engine speed to the desired roll-off point. Turn the potentiometer clockwise until the voltage starts to drop off. Then adjust the potentiometer counter-clockwise until the voltage returns to rated. Re-adjust engine speed to rated speed.

## MARATHON ELECTRIC SE SERIES AUTOMATIC VOLTAGE REGULATOR OPERATIONAL TEST

### OPERATIONAL TEST PROCEDURE

1. Connect the test setup as shown in Figure 1. Do not apply power. Insure that the light bulbs are 120 volt, and less than 100 Watts.
2. Adjust the regulator VAR and/or remote VAR and the STABILITY ADJUST to maximum CCW.
3. Apply 240 volts AC, 50/60 Hz power to the regulator. The light bulbs should remain off.
4. Slowly adjust the regulator VAR clockwise. At the regulation point, the light bulbs should illuminate. Small adjustments above and below this level should cause the light bulbs to go on and off. Note that the light bulbs go on and off rapidly.
5. Rotate the STABILITY ADJUST FULLY clockwise. Now adjust the regulator VAR above and below the regulation point. The light bulbs should still go on and off, but the transition from off to on (and vice versa) should be much slower than in step 4 above.

## START-UP PROCEDURE

### PRELIMINARY SET-UP

Ensure the voltage regulator is correctly connected to the generator. Refer to the specific connection diagram supplied with the generator.

Set the regulator voltage adjust to full counter-clockwise (minimum voltage level).

Set the remote voltage adjust (if used) to the center position.

Set the stability control full clockwise (maximum stability level).

Connect the positive lead of a 100V D.C. voltmeter to F1 and the negative lead of the voltmeter to F2 or use an appropriate AC voltmeter on the generator output leads.

### SYSTEM START-UP

Start and run the generator at no load and rated speed. The generator voltage should build up to a minimum level. (Actual level is dependent upon connection). If it does not build up, refer to field flashing section in generator manual.

Slowly adjust the voltage control until the generator voltage reaches the nominal value. If used, adjust the remote voltage rheostat to set the generator voltage to the exact value desired.

Turn the stability adjust counter-clockwise until instability is shown on either of the voltmeters mentioned in the "PRELIMINARY SET-UP" section. With the system operating in an unstable condition, slowly adjust the stability control clockwise until generator stability is reached.

Interrupt regulator power for a short time (approximately 1-2 seconds).

If the generator remains stable, no further adjustment is necessary. If the generator does not remain stable, increase the stability slightly and interrupt regulator power again.

This procedure should be repeated until system stability is reached and maintained.

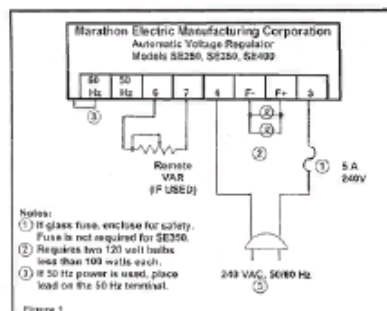

SYMPTOM	CAUSE	ACTION
Residual Voltage - No Output	Residual voltage at regulator power input wires 3 & 4 below 10Vac.  Acceleration time to rated speed too long.  Field leads F1, F2 not connected. Power input leads not connected. Blown or missing fuse. Defective regulator. Defective generator.	Check wiring diagram for proper connections.  Flash generator field. Refer to field flashing section in generator manual.  Reduce acceleration time.  Interrupt power input to regulator after achieving rated speed.  Connect field leads F1, F2.  Connect power input leads 3, 4.  Replace fuse.  Replace regulator.  Consult generator manual.
Output Voltage Low	Incorrect connections.  Voltage adjust turned down.  Remote voltage adjust is turned down.  Defective regulator.	Check wiring diagram for proper connections.  Rotate voltage adjust CW until desired voltage is reached.  Rotate remote voltage adjust CW until desired voltage is reached.  Replace regulator.
Output Voltage High	Voltage adjust turned too high.  Remote voltage adjust is turned too high.	Rotate voltage adjust CCW until desired voltage is reached.  Rotate remote voltage adjust CCW until desired voltage is reached.
Output Voltage High - No Adjustment	Defective regulator.	Replace regulator.
Remote Voltage Adjust Operates Backwards	Voltage adjust wire backwards.	Reverse the wiring of the remote voltage adjust.
Generator Output Voltage Hunting	Stability adjust not set properly.	Rotate the stability adjust in a CW direction until hunting stops.
Poor Regulation	Defective regulator.	Replace regulator.

## marathon™ Generators

100 E. Randolph Street (54401)  
PO Box 8003  
Wausau, WI 54402-8003 U.S.A.  
PH: 715-675-3359  
FAX: 715-675-8026

[www.marathonelectric.com](http://www.marathonelectric.com)

A Regal Brand



[www.regalbelloit.com](http://www.regalbelloit.com)